

Clarion®

Owner's manual
Mode d'emploi
Manual de instrucciones

DRX9575Rz

RDS-FM/AM CD PLAYER
WITH CD/MD CHANGER CONTROL

RADIO RDS-FM/AM/LECTEUR CD AVEC
COMMANDE DE CHANGEUR CD/MD

RADIO DE RDS-FM/AM Y REPRODUCTOR DE
DISCOS COMPACTOS CON CONTROL DE
CARGADOR DE DISCOS COMPACTOS/
MINIDISCOS

ProAudio

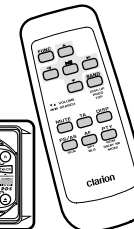
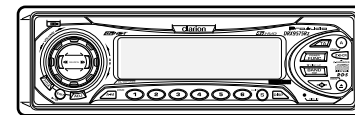

Clarion Co., Ltd.

All Rights Reserved. Copyright © 1998: Clarion Co., Ltd.
Printed in Singapore / Imprimé au Singapour / Impreso en Singapur

PE-2177B
280-7299-00

Thank you for purchasing the **Clarion DRX9575Rz**.

- * Please read this owner's manual in its entirety before operating this equipment.
- * After reading this manual, be sure to keep it in a handy place (e.g., glove compartment).
- * Check the contents of the enclosed warranty card and keep it carefully with this manual.
- * This manual includes the operating procedures of the CD changer, MD changer, TV tuner and digital sound processor (DSP) connected via the CeNET cable. The CD changer, MD changer, TV tuner and DSP have their own manuals, but no explanations for operating them are described.

Contents

1. FEATURES	2
2. PRECAUTIONS	3
Handling Compact Discs	4
Sloping Console	4
3. CONTROLS	5
4. NOMENCLATURE	6
Names of Buttons	6
Display Items	6
LCD Screen	6
5. DCP	7
6. REMOTE CONTROL	8
Inserting the Batteries	8
Functions of Remote Control Unit Buttons	9
7. OPERATIONS	10
Basic Operations	10
Radio Operations	13
RDS Operations	14
CD Operations	17
Other Handy Functions	18
8. OPERATION OF ACCESSORIES	21
CD Changer Operations	21
MD Changer Operations	23
TV Operations	25
DSP Operations	26
9. TROUBLESHOOTING	30
10. ERROR DISPLAYS	31
11. SPECIFICATIONS	32

1. FEATURES

- Rotary Encoder Volume Control with Multi-Color Prism Key
- Touch-n-GO Motorized Sloping Console Detachable Face
- High Visibility 8-Color Dot Matrix Large LC Display
- RDS Receiver, **MAGITUNE**® FM Reception System
- Controller for Optional DSP/EQ, AMP. & TV Tuner Modules
- Capability to Read CD TEXT Data from Clarion Compatible CD Changer
- Z-Enhancer with 3 Adjustment Modes
- CeNET with Balanced Audio Line Transmission and Dynamic Noise Canceling
- 8-Times Oversampling Digital Filter and Dual 1-Bit D/A Converters
- Zero-Bit Detector™ Mute Circuit
- 4V/4-Channel RCA Line Level Output with Fader Control
- 4V/2-Channel Non-Fade RCA Line Level Output with Volume Control
- 1 Optical Digital Output

6. REMOTE CONTROL

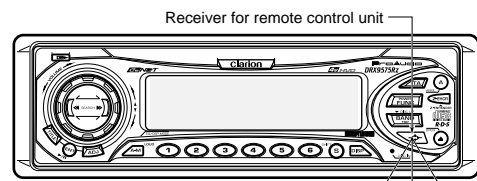

Operating range: 30° in all directions

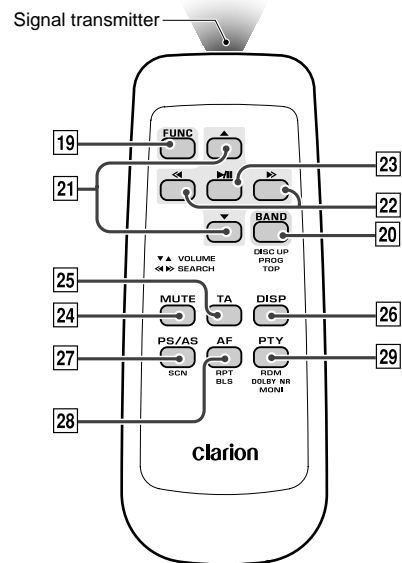

Remote control unit

Inserting the Batteries

1. Turn the remote control unit over, then slide the rear cover in the direction of the arrow.
2. Insert the AA (UM-3/1.5V) batteries that came with the remote control unit facing in the directions shown in the figure, then close the rear cover.

Notes:

Using batteries improperly can cause them to explode. Take note of the following points:

- When replacing batteries, replace both batteries with new ones.
- Do not short-circuit, disassemble or heat batteries.
- Do not dispose of batteries into fire or flames.
- Dispose of spent batteries properly.

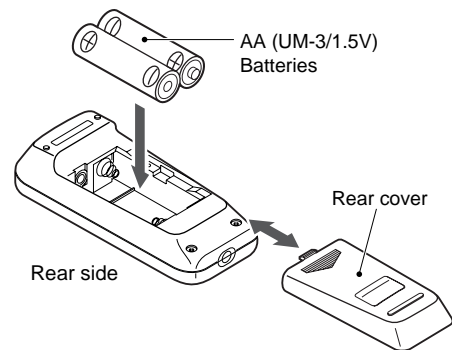

2. PRECAUTIONS

1. When the inside of the car is very cold and the player is used soon after switching on the heater moisture may form on the disc or the optical parts of the player and proper playback may not be possible. If moisture forms on the disc, wipe it off with a soft cloth. If moisture forms on the optical parts of the player, do not use the player for about one hour. The condensation will disappear naturally allowing normal operation.
2. Driving on extremely bumpy roads which cause severe vibration may cause the sound to skip.
3. This unit uses a precision mechanism. Even in the event that trouble arises, never open the case, disassemble the unit, or lubricate the rotating parts.

This equipment has been tested and found to comply with the limits for a Class B digital device, pursuant to Part 15 of the FCC Rules.

These limits are designed to provide reasonable protection against harmful interference in a residential installation.

This equipment generates, uses, and can radiate radio frequency energy and, if not installed and used in accordance with the instructions, may cause harmful interference to radio communications. However, there is no guarantee that interference will not occur in a particular installation.

If this equipment does cause harmful interference to radio or television reception, which can be determined by turning the equipment off and on, the user is encouraged to consult the dealer or an experienced radio/TV technician for help.

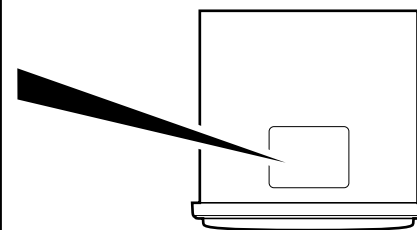
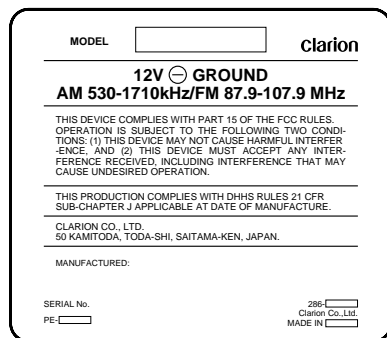

Bottom View of Source Unit

CAUTION

USE OF CONTROLS, ADJUSTMENTS, OR PERFORMANCE OF PROCEDURES OTHER THAN THOSE SPECIFIED HEREIN, MAY RESULT IN HAZARDOUS RADIATION EXPOSURE.

THE COMPACT DISC PLAYER and MINI DISC PLAYER SHOULD NOT BE ADJUSTED OR REPAIRED BY ANYONE EXCEPT PROPERLY QUALIFIED SERVICE PERSONNEL.

CHANGES OR MODIFICATIONS NOT EXPRESSLY APPROVED BY THE MANUFACTURER FOR COMPLIANCE COULD VOID THE USER'S AUTHORITY TO OPERATE THE EQUIPMENT.

INFORMATION FOR USERS:

CHANGES OR MODIFICATIONS TO THIS PRODUCT NOT APPROVED BY THE MANUFACTURER WILL VOID THE WARRANTY AND WILL VIOLATE FCC APPROVAL.

Handling Compact Discs

Use only compact discs bearing the mark.

Do not play heart-shaped, octagonal, or other specially shaped compact discs.

Handling

- New discs may have some roughness around the edges. If such discs are used, the player may not work or the sound may skip. Use a ball-point pen or the like to remove any roughness from the edge of the disc.

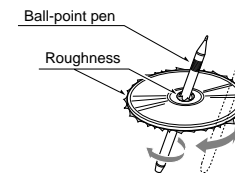

- Never stick labels on the surface of the compact disc or mark the surface with a pencil or pen.
- Never play a compact disc with any cellophane tape or other glue on it or with peeling off marks. If you try to play such a compact disc, you may not be able to get it back out of the CD player or it may damage the CD player.
- Do not use compact discs that have large scratches, are misshapen, cracked, etc. Use of such discs may cause misoperation or damage.

- To remove a compact disc from its storage case, press down on the center of the case and lift the disc out, holding it carefully by the edges.
- Do not use commercially available CD protection sheets or discs equipped with stabilizers, etc. These may damage the disc or cause breakdown of the internal mechanism.

Storage

- Do not expose compact discs to direct sunlight or any heat source.
- Do not expose compact discs to excess humidity or dust.
- Do not expose compact discs to direct heat from heaters.

Cleaning

- To remove fingermarks and dust, use a soft cloth and wipe in a straight line from the center of the compact disc to the circumference.
- Do not use any solvents, such as commercially available cleaners, anti-static spray or thinner to clean compact discs.
- After using special compact disc cleaner, let the compact disc dry off well before playing it.

Sloping Console

The DRX9575Rz use sloping consoles to make large-screen displays possible.

CAUTION

Be careful not to get your fingers caught when opening and closing the SLOPING CONSOLE.

1. For safety's sake, always close the SLOPING CONSOLE before leaving this unit unused for a prolonged period or switching OFF the ignition key.

If you switch OFF the ignition key with the SLOPING CONSOLE tilted, the SLOPING CONSOLE does not close.

2. Before the SLOPING CONSOLE closes, there may be a braking sound from the safety mechanism. This is normal.

3. If you move the SLOPING CONSOLE by hand, this may create play. To correct this play, with the power on for the unit, press A button [7] to close the SLOPING CONSOLE.

4. After a CD is ejected, the SLOPING CONSOLE automatically returns to the tilted or closed state. If there is any obstruction when the SLOPING CONSOLE tries to close, the safety mechanism is triggered and the SLOPING CONSOLE returns to the open state. If this happens, remove the obstruction, then press OPEN button [9] or A button [7].

Be sure to unfold and read the next page.
 Veuillez déplier et vous référer à la page suivante.
 Cerciórese de desplegar y de leer la página siguiente.

3. CONTROLS / LES COMMANDES / CONTROLES

Source unit / Appareil pilote / Unidad fuente

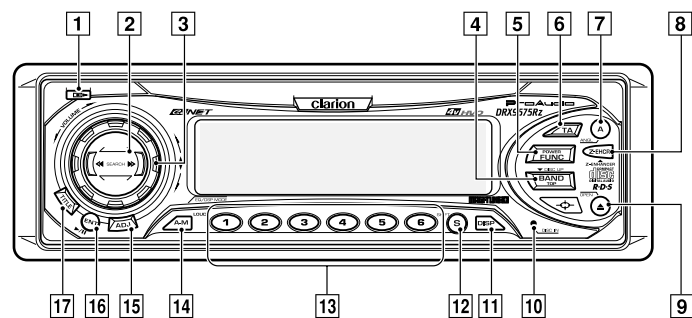

With the SLOPING CONSOLE opened / Ouvrez la CONSOLE RABATTABLE /
Apertura de la CONSOLA INCLINABLE

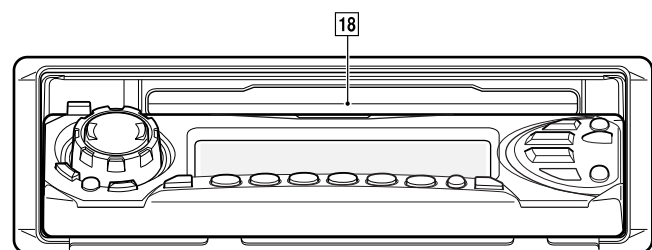

Display / Afficheur / Visualizador

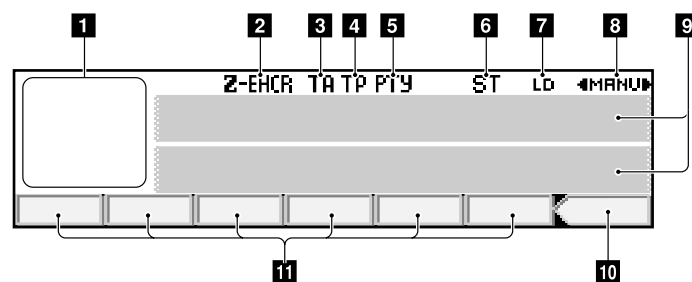

Note: Be sure to unfold this page and refer to the front diagrams as you read each chapter.
Remarque: Veuillez déplier cette page et vous référer aux schémas quand vous lisez chaque chapitre.
Nota: Cuando lea los capítulos, despliegue esta página y consulte los diagramas.

4. NOMENCLATURE

Note:

• Be sure to read this chapter referring to the front diagrams of chapter "3. CONTROLS" on page 5 (unfold).

Names of Buttons

- | | |
|------------------------------------|----------------------------|
| 1 Release button | 10 DISC IN indicator |
| 2 SEARCH button | 11 DISP (display) button |
| 3 Rotary knob | 12 S (shift) button |
| 4 BAND button | 13 Preset buttons (1 to 6) |
| TOP button | Direct buttons (1 to 6) |
| 5 POWER button | 14 A-M (audio mode) button |
| FUNC (function) button | LOUD (loudness) button |
| 6 TA (traffic announcement) button | 15 ADJ (adjust) button |
| 7 A (angle) button | 16 ENT (enter) button |
| 8 Z-EHCR (z-enhancer) button | Play/pause button |
| 9 Eject button | 17 TITLE button |
| OPEN button | 18 CD insertion slot |

Display Items (Function mode)

- | | |
|--|---|
| 1 Function icon | 9 • in Radio Mode |
| 2 Z-EHCR (z-enhancer) indication | Band, programe type, frequency, etc. |
| 3 TA (traffic announcement) indication | • in CD Mode |
| 4 TP (traffic programe) indication | Truck no., play time, user title, etc. |
| 5 PTY (programe type) indication | • in CD Changer Mode |
| 6 ST (stereo) indication | Truck no., play time, user title, CD-TEXT, etc. |
| 7 LD (loudness) indication | • in MD Changer Mode |
| 8 MANU (manual) indication | Truck no., play time, MD title, etc. |
| | • in TV Mode |
| | Band, channel no., user title, etc. |
| | 10 P.ch (preset channel) or SUB indication |
| | 11 Preset channel indication |
| | Sub menu indication |

LCD Screen

- In extreme cold, the screen movement may slow down and the screen may darken, but this is normal. The screen will recover when it returns to normal temperature.
- The colors displayed on the LCD screen vary with the heat of this unit and the temperature in the car. This is a characteristic of LCDs and is normal. The display colors return to normal when the LCD screen returns to normal temperature.

5. DCP

The control panel can be detached to prevent theft. When detaching the control panel, store it in the DCP (DETACHABLE CONTROL PANEL) case to prevent scratches.

We recommend taking the DCP with you when leaving the car.

Removing the DCP

- With the SLOPING CONSOLE closed, turn off the power.
- Press the Release button 1 deeply to open the DCP.

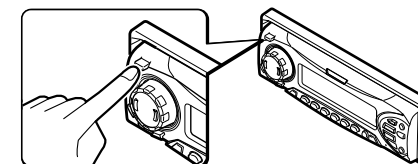

- Pull the DCP toward you and remove it.

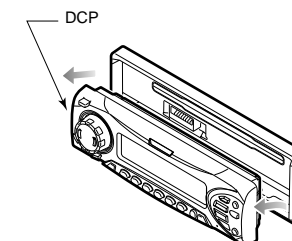

CAUTION

- Always close the SLOPING CONSOLE before removing the DCP.
- If you remove the DCP with the SLOPING CONSOLE open, the SLOPING CONSOLE closes immediately. Be careful not to get your fingers caught.

Attaching the DCP

- Insert the DCP so that the (A) section on the right side of the DCP catches on the hook (B) on the unit.

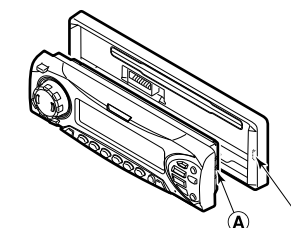

- Press the left side of the DCP carefully to fit it in place.

CAUTION

- The DCP can easily be damaged by shocks. After removing it, be careful not to drop it or subject it to strong shocks.
- If the Release button 1 is pressed and the DCP is not locked into place, it may fall out from vibration of the car. This can break the DCP, so after removing it, either install it on the unit or put it in its DCP case.
- The connector connecting the unit and the DCP is an extremely important part. Be careful not to damage it by pressing on it with fingernails, screwdrivers, etc.

Note:

- If the DCP is dirty, wipe off the dirt with a soft, dry cloth only.

Functions of Remote Control Unit Buttons

Button	Mode	Radio (RDS)	CD	CD changer MD changer	TV
19	FUNC	Turns power on and off. When pressed and held for 1 second: Turns power off. Switches among radio, CD, CD changer, MD changer and TV.			
20	BAND DISC UP PROG TOP	Switches reception band.	Plays the first track. Top play.	Moves the next disc in increasing order.	Switches reception band.
21	VOLUME	Increases and decreases volume (in all modes).			
22	SEARCH	Moves preset channels up and down.	Moves tracks up and down. When pressed and held for 1 second: Fast-forward/ fast-backward.	Moves tracks up and down. When pressed and held for 1 second: Fast-forward/ fast-backward.	Moves preset channels up and down.
23	PLAY/PAUSE	No function.	Switches between playback and pause.	Switches between playback and pause.	No function.
24	MUTE	Turns mute on and off.			
25	TA	TA on and off.			
26	DISP	Switches among main display, clock display, spectrum analyzer display (only when connected to DPH7500z) and screen saver display.			
27	PS/AS SCN	Preset scan. When pressed and held for 2 seconds: Auto store.	Scan play.	Scan play. When pressed and held for 1 second: Disc scan play.	Preset scan. When pressed and held for 2 seconds: Auto store.
28	AF RPT BLS	AF function on and off.	Repeat play.	Repeat play. When pressed and held for 1 second: Disc repeat play.	No function.
29	PTY RDM DOLBY NR MONI	PTY standby mode on and off.	Random play.	Random play. When pressed and held for 1 second: Disc random play.	Switches between TV and VTR.

* Some of the corresponding buttons on the source unit and remote control unit have different functions.

7. OPERATIONS

Basic Operations

Note: Be sure to read this chapter referring to the front diagrams of chapter "3. CONTROLS" on page 5 (unfold).

⚠ CAUTION

Be sure to lower the volume before switching off the unit power or the ignition key. The unit remembers its last volume setting. If you switch the power off with the volume up, when you switch the power back on, the sudden loud volume may hurt your hearing and damage the unit.

The clock is displayed when the ignition key is turned to the ACC (accessory) or IGN (ignition-on) position even when the unit power is off. In some cars, the clock may momentarily disappear when the ignition key is turned to the START position. The clock will reappear after the engine has started and the ignition key is released to the IGN (ignition-on) position.

Turning on/off the power

Note:

- Be careful about using this unit for a long time without running the engine. If you drain the car's battery too far, you may not be able to start the engine and this can reduce the service life of the battery.

1. Press POWER button [5].
2. The illumination and display on the unit light up. The unit automatically remembers its last operation mode and will automatically switch to display that mode.
3. Press and hold POWER button [5] for 1 second or longer to turn off the power for the unit.

Note:

- About the system check

The confirmation of connected equipments must be performed for this unit only when the wiring connection is complete and power is turned on to the unit first. When the power is supplied, "SYSTEM CHECK" appears in the display. Press POWER button [5]. The system check starts inside the unit. The equipments connected to this unit appears in the display. Press POWER button [5] again.

Selecting a mode

1. Press FUNC button [5] to change the mode of operation.

2. Each time you press FUNC button [5], the mode of operation changes in the following order:

Radio mode → CD mode → CD changer mode → MD changer mode → TV mode → Radio mode...

* External equipment not connected with CeNET is not selected.

Adjusting the volume

Turning the Rotary knob [3] clockwise increases the volume; turning it counterclockwise decreases the volume.

* The volume level is from 00 (minimum) to 33 (maximum).

Switching the display

Press DISP button [11] to select the desired display. Each time you press DISP button [11], the display switches in the following order:

Main display



Clock display



Spectrum analyzer display



Screen saver display

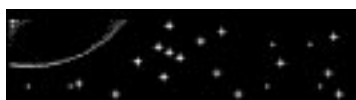

Main display...

- * The spectrum analyzer display is only displayed when the DPH7500z is connected.
- * Once selected, the preferred display becomes the display default. When a function adjustment such as volume is made, the screen will momentarily switch to that function's display, then revert back to the preferred display several seconds after the adjustment.
- * If a title has been input, it is displayed in the main display. If no title has been input, "-----" appears in the display. To input a title, refer to the subsection in "Entering titles" in "Other Handy Functions" section.

Changing the angle of the SLOPING CONSOLE

If the installation position or display angle makes the display hard to see, change the angle of the SLOPING CONSOLE.

1. Press A button [7].
2. Each time this button is pressed, the SLOPING CONSOLE switches to the tilted or closed state.

⚠ CAUTION

When not using this unit for a long time and when turning OFF the ignition key for the car, close the SLOPING CONSOLE for safety's sake.

Switching the screen saver

You can switch between 2 screen savers.

1. Press DISP button [11] and select the screen saver display.
2. Each time you press and hold DISP button [11] for 1 second or longer, the screen saver changes between 2 screen savers.

Setting the Z-enhancer

This unit comes with 3 types of sound tone effect stored in memory. Select the one you prefer.

- * The factory default setting is "Z-EHCR OFF".

Each time you press Z-EHCR button [8], the tone effect changes in the following order:

"Z-EHCR 1" → "Z-EHCR 2" → "Z-EHCR 3" → "Z-EHCR OFF" → "Z-EHCR 1"...

When a Z-enhancer comes on (1-3), "Z-EHCR" lights in the display.

- Z-enhancer 1:
Setting emphasizing bass
- Z-enhancer 2:
Setting emphasizing treble

- Z-enhancer 3:
Setting emphasizing bass and treble
- OFF:
Neither bass nor treble emphasized by Z-enhancer

Adjusting the tone

Press A-M button [14] and select the item to adjust. Each time you press A-M button [14], the item changes in the following order:

- When the Z-enhancer and tone bypass are off
"NON-FADER VOL" → "TONE BYPASS" → "SOUND" → "POSITION" → Function mode...
- When Z-enhancer 1, 2 or 3 is set
"NON-FADER VOL" → "Z-ENHANCER" → "POSITION" → Function mode...

Note:

- When the separately-sold digital sound processor (DPH7500z) is used, the tone bypass, bass and treble tone adjustments cannot be selected. To adjust the tone, see the chapter "DSP Operations".

Adjusting the non-fader output volume

You can adjust the volume output from the unit's non-fader output terminal.

1. Press A-M button [14] and select "NON-FADER VOL".
2. Turning the Rotary knob [3] clockwise increases the output volume; turning it counterclockwise decreases the output volume.
 - * The factory default setting is "4". (Setting range: 0 to 7)
3. When the adjustment is complete, press A-M button [14] several times until the function mode is reached.

Setting tone bypass

The tone bypass disables the tone (bass and treble) functions and cuts the noise generated when the tone functions are on.

1. Press A-M button [14] and select "TONE BYPASS".
2. Turning the Rotary knob [3] clockwise sets the tone bypass to "YES" (ON); turning it counterclockwise sets the tone bypass to "NO" (OFF).
 - * The factory default setting is "NO" (OFF).
 - * If the setting is "YES" (ON), the bass and treble adjustments cannot be made.
3. When the adjustment is complete, press A-M button [14] several times until the function mode is reached.

Note:

- If a Z-enhancer (1-3) is ON, tone bypass cannot be set.

Adjusting the bass

1. Press A-M button [14] and select "SOUND".
2. Press the right or left side of SEARCH button [2] to select "BASS".
3. Turning the Rotary knob [3] clockwise emphasizes the bass; turning it counterclockwise attenuates the bass.
 - * The factory default setting is "0". (Adjustment range: -6 to +6)
 - * The bass cannot be adjusted if the tone bypass setting is "YES" (ON).
4. When the adjustment is complete, press A-M button [14] several times until the function mode is reached.

Adjusting the treble

1. Press A-M button [14] and select "SOUND".
2. Press the right or left side of SEARCH button [2] to select "TREBLE".
3. Turning the Rotary knob [3] clockwise emphasizes the treble; turning it counterclockwise attenuates the treble.
 - * The factory default setting is "0". (Adjustment range: -6 to +6)
 - * The treble cannot be adjusted if the tone bypass setting is "YES" (ON).
4. When the adjustment is complete, press A-M button [14] several times until the function mode is reached.

Adjusting the balance

1. Press A-M button [14] and select "POSITION".
2. Press the right or left side of SEARCH button [2] to select "L/R" (LEFT/RIGHT).
3. Turning the Rotary knob [3] clockwise emphasizes the sound from the right speaker; turning it counterclockwise emphasizes the sound from the left speaker.
 - * The factory default setting is "0". (Adjustment range: LEFT13 to RIGHT13)
4. When the adjustment is complete, press A-M button [14] several times until the function mode is reached.

Adjusting the fader

1. Press A-M button [14] and select "POSITION".
2. Press the right or left side of SEARCH button [2] to select "F/R" (FRONT/REAR).

3. Turning the Rotary knob [3] clockwise emphasizes the sound from the front speakers; turning it counterclockwise emphasizes the sound from the rear speakers.
 - * The factory default setting is "0". (Adjustment range: FRONT12 to REAR12)
4. When the adjustment is complete, press A-M button [14] several times until the function mode is reached.

Adjusting the Z-enhancer

1. Press Z-EHCR button [8] and select the Z-enhancer mode (1-3) to adjust.
2. Press A-M button [14] and select "Z-ENHANCER".
3. Turning the Rotary knob [3] clockwise adjusts in the + direction; turning it counterclockwise adjusts in the - direction.
 - * When Z-Enhancer 1 is selected, you can adjust the bass in the range of ± 2 .
 - * When Z-Enhancer 2 is selected, you can adjust the treble in the range of ± 2 .
 - * When Z-Enhancer 3 is selected, you can adjust the bass and treble in the range of ± 2 .
4. When the adjustment is complete, press A-M button [14] several times until the function mode is reached.

Note:

- If a Z-enhancer (1-3) is ON, tone bypass cannot be set.

Turning on/off the loudness

The loudness effect emphasizes the bass and treble to create a natural sound tone. When you are listening to music at a low volume, it is recommended to use the loudness effect.

1. Press and hold LOUD button [14] for 1 second or longer to turn on the loudness effect. When the loudness effect is turned on, "LD" lights in the display.
2. Press and hold LOUD button [14] for 1 second or longer to turn off the loudness effect. "LD" goes off in the display.

Note:

- When using a sold separately digital sound processor (DPH7500z), a feature called auto loudness is selected. This function is different from the loudness effect. For further details on the auto loudness feature, refer to the subsection "Output adjustment of auto loudness, subwoofer and playback band".

FM Reception

For enhanced FM performance the **MAGITUNE3**® tuner includes signal actuated stereo control, Enhanced Multi AGC, Impulse noise reduction circuits and Multipath noise reduction circuits.

Listening to the radio

1. Press FUNC button [5] and select the radio mode. The frequency or PS is displayed.
 - * PS: Programe service name
2. Press BAND button [4] and select the radio band. Each time the button is pressed, the radio reception band changes in the following order:
FM1 → FM2 → FM3 → AM → FM1...
3. Press the right or left side of SEARCH button [2] to tune in the desired station.

Tuning

There are 3 types of tuning mode available, seek tuning, manual tuning and preset tuning.

Seek tuning

1. Press BAND button [4] and select the desired band. (FM or AM)
 - * If "MANU" is lit in the display, press and hold BAND button [4] for 1 second or longer. "MANU" in the display goes off and seek tuning is now available.
2. Press the right or left side of SEARCH button [2] to automatically seek a station.
When the right side of SEARCH button [2] is pressed, the station is sought in the direction of higher frequencies; if the left side of SEARCH button [2] is pressed, the station is sought in the direction of lower frequencies.

Manual tuning

There are 2 ways available: Quick tuning and step tuning.

When you are in the step tuning mode, the frequency changes one step at a time. In quick tuning mode, you can quickly tune the desired frequency.

1. Press BAND button [4] and select the desired band. (FM or AM)
 - * If "MANU" is not lit in the display, press and hold BAND button [4] for 1 second or longer. "MANU" is lit in the display and manual tuning is now available.
2. Tune into a station.

● Quick tuning:

Press and hold the right or left side of SEARCH button [2] for 1 second or longer to tune in a station.

● Step tuning:

Press the right or left side of SEARCH button [2] to manually tune in a station.

Recalling a preset station

A total of 24 preset positions (6-FM1, 6-FM2, 6-FM3, 6-AM) exist to store individual radio stations in memory. Pressing the corresponding preset button recalls the stored radio frequency automatically.

1. Press BAND button [4] and select the desired band. (FM or AM)
2. Press S button [12] to display the preset channel display.
3. Press the corresponding Preset button [13] to recall the stored station.
 - * Press and hold one of Preset buttons [13] for 2 seconds or longer to store that station into preset memory.

Manual memory

1. Press BAND button [4] and select the desired band. (FM or AM)
2. Press S button [12] to display the preset channel display.
3. Select the desired station with seek tuning, manual tuning, or preset tuning.
4. Press and hold one of Preset buttons [13] for 2 seconds or longer to store the current station into preset memory.

Auto store

Auto store is a function for storing up to 6 stations that are automatically tuned in sequentially. If 6 receivable stations cannot be received, a previously stored station remains unoverwritten at the memory position.

1. Press BAND button [4] and select the desired band. (FM or AM)
2. Press S button [12] to display the subdisplay.
3. Press and hold the number "2" of Preset buttons [13] for 2 seconds or longer. The stations with good reception are stored automatically to the preset channels.
 - * If auto store is performed in the FM bands, the stations are stored in FM3 even if FM1 or FM2 was chosen for storing stations.

Preset scan

Preset scan receives the stations stored in preset memory in order. This function is useful when searching for desired station in memory.

1. Press S button **[12]** to display the subdisplay.
2. Press the number "1" of Preset buttons **[13]**.
3. When the desired station is tuned in, press the number "1" of Preset buttons **[13]** again to continue receiving that station.

RDS (Radio Data System)

This unit has a built in RDS decoder system that supports broadcast stations transmitting RDS data. This system can display the name of the broadcast station being received (PS) and can automatically switch to the broadcast station with the best reception as you move long distances (AF switching). Also, if a traffic announcement or programe type are broadcast from an RDS station, no matter what mode you are in, this broadcast is received.

When using the RDS function, always set the radio to FM mode.

- AF : Alternative Frequency
- PS : Programe Service Name
- PTY : Programe Type
- TP : Traffic Programe

* RDS interrupt do not function during AM radio reception or in TV mode.

AF function

The AF function switches to a different frequency on the same network in order to maintain optimum reception.

* The factory default setting is "ON".

● Switching OFF the AF function

1. Press S button **[12]** to display the subdisplay.
2. Press the number "3" of Preset buttons **[13]**.
The color in the "AF" frame in the display goes off and the AF function turns off.

● Switching ON the AF function

1. Press S button **[12]** to display the subdisplay.
2. Press the number "3" of Preset buttons **[13]**.
The color in the "AF" frame in the display lights up and the AF function turns on.
 - * If the reception of the current broadcast station deteriorates, "SEARCH" appears in the display and the radio searches for the same programe on another frequency.
 - * When AF is ON, if an RDS broadcast is being received, the AF frame in the display is green and if an RDS broadcast is not being received, the AF frame is red.

TA (Traffic Announcement)

In TA standby mode, when a traffic announcement broadcast starts, the traffic announcement broadcast is received as top priority regardless of the function mode so you can listen to it. Traffic programme (TP) automatic tuning is also possible.

* This function can only be used when "TP" is lit in the display. When "TP" is lit, this means that the RDS broadcast station being received has traffic announcement programmes.

● Setting TA standby mode

If you press TA button [6] when only "TP" is lit in the display, "TP" and "TA" light in the display and the unit is set into TA standby mode until a traffic announcement is broadcast. When a traffic announcement broadcast starts, "TRA INFO" appears in the display. If you press TA button [6] while a traffic announcement broadcast is being received, the traffic announcement broadcast reception is canceled and the unit goes into TA standby mode.

● Canceling TA standby mode

With "TP" and "TA" lit in the display, press TA button [6]. The "TA" in the display goes off and TA standby mode is canceled.

* If "TP" is not lit, pressing TA button [6] searches for a TP station.

● Searching for a TP station

When "TP" is not lit, if you press TA button [6], the "TA" in the display lights and the unit automatically receives a TP station.

Note:

• If a TP station is not received, the unit continues the search operation. Pressing TA button [6] again goes off the "TA" in the display and stops TP station searching.

Auto store function for TP stations

You can automatically store up to 6 TP stations into preset memory. If the number of TP that can be received is less than 6, broadcast stations already stored in memory are left without being overwritten.

1. With "TA" lit in the display, press S button [12] to display the subdisplay.
2. Press and hold the number "2" of Preset buttons [13] for 2 seconds or longer. The TP stations with the good reception sensitivity are stored into preset memory.

* Even if you select FM1 or FM2, a TP station is stored into memory for FM3.

PTY

This function enables you to listen to a broadcast of the selected programme type when it starts even if the unit is ON a function mode other than radio.

* Some countries do not yet have PTY broadcast.
* In TA standby mode, a TP station has priority over a PTY broadcast station.

● Setting PTY standby mode

1. Press S button [12] to display the subdisplay.
2. When you press the number "6" of Preset buttons [13], "PTY" lights in the display and the PTY standby mode is turned on. When the selected PTY broadcast starts, the PTY item name appears in the display.

● Canceling PTY standby mode

1. Press S button [12] to display the subdisplay.
2. When you press the number "6" of Preset buttons [13], "PTY" goes off in the display and PTY standby mode is canceled.

● Canceling a PTY interrupt broadcast

1. Press S button [12] during the PTY interrupt broadcast to display the subdisplay.
2. If you press the number "6" of Preset buttons [13], the PTY interrupt is canceled and the unit returns to PTY standby mode.

Selecting PTY

1. Press S button [12] to display the subdisplay.
2. When you press the number "5" of Preset buttons [13], the unit goes into PTY select mode.
3. Press any one of Preset buttons [13]. Alternatively, turn the Rotary knob [3] clockwise or counterclockwise to select the desired PTY.

* Below are the factory default settings stored for Preset buttons [13].

Preset No.	PTY	
1	NEWS	News
2	TOP 40	Top 40
3	COUNTRY	Country music
4	SOFT	Soft music
5	CLASSICL	Classic music
6	R & B	Rhythm and Blues

4. The PTY select mode is canceled automatically 7 seconds after a PTY is selected.

PTY seek

1. Press S button [12] to display the subdisplay.
2. When you press the number "5" of Preset buttons [13], the PTY select mode is turned on.
3. Select PTY.
4. Press the right or left side of SEARCH button [2]. If you press the right side, the unit seeks a PTY broadcast moving up the frequencies; if you press the left side, it seeks moving down the frequencies.
 - * If no station with the selected PTY broadcast can be received, the unit returns to PTY select mode.

PTY preset memory

1. Press S button [12] to display the subdisplay.
2. When you press the number "5" of Preset buttons [13], the PTY select mode is turned on.
3. Turn the Rotary knob [3] clockwise or counterclockwise to select the desired PTY.

The 22 types of PTY below can be selected.

PTY (Program Type)	
NEWS	News
INFORM	Information
SPORTS	Sports
TALK	Talk
ROCK	Rock
CLS ROCK	Classic Rock
ADLT HIT	Adult Hits
SOFT RCK	Soft Rock
TOP 40	Top 40
COUNTRY	Country music
OLDIES	Oldies
SOFT	Soft music
NOSTALGA	Nostalgia
JAZZ	Jazz
CLASSICL	Classical
R & B	Rhythm and Blues
SOFT R&B	Soft Rhythm and Blues
LANGUAGE	Language
REL MUSC	Religious music
REL TALK	Religious talk
PERSNLTY	Personality
PUBLIC	Public

4. If you press and hold any one of Preset buttons [13] for 2 seconds or longer, the selected PTY is stored into that preset channel memory.

Emergency broadcast

If an emergency broadcast is received, all the function mode operations are stopped. "ALERT !" appears in the display and the emergency broadcast can be heard.

● Canceling an emergency broadcast

1. Press S button [12] to display the subdisplay.
2. If you press the number "3" of Preset buttons [13], emergency broadcast reception is canceled.

Volume setting of TA, emergency broadcast (ALERT) and PTY

The volume for TA, ALERT and PTY interrupts can be set during TA, ALERT or PTY interrupt.

* The factory default setting is "15".

During a TA, ALERT or PTY interrupt, turn the Rotary knob [3] clockwise or counterclockwise to set the volume to the desired level (00 to 33).

* When the TA, ALERT or PTY interrupt ends, the volume returns to the level it had before the interrupt.

CD Operations

Loading a CD

1. Press OPEN button [9]. The SLOPING CONSOLE opens.

⚠ CAUTION

Be careful not to get your fingers caught when opening and closing the SLOPING CONSOLE.

2. Insert a CD into the center of the insertion slot with the label side facing up. The CD plays automatically after loading.

Notes:

- Never insert foreign objects into the CD insertion slot.
- If the CD is not inserted easily, there may be another CD in the mechanism or the unit may require service.
- Discs not bearing the  mark and CD-ROMs cannot be played by this unit.

Loading 3" (8 cm) compact discs

- * No adapter is required to play a 3" CD.
 - * Insert the 3" CD into the center of the insertion slot.
 - * When a 3" CD is loaded, "SINGLE" lights in the display.
3. After loading a CD, the SLOPING CONSOLE closes automatically.

Notes:

- Note that SLOPING CONSOLE close immediately after a CD is inserted into CD insertion slot.
- If no CD is loaded in the SLOPING CONSOLE, it closes after 30 seconds.

Listening to a CD already inserted

Press FUNC button [5] to select the CD mode. Play starts automatically. If no CD is loaded in the unit, "NO DISC" appears in the display.

Pausing play

1. Press Play/pause button [16] to pause play. "PAUSE" appears in the display.
2. To resume CD play, press Play/pause button [16] again.

Ejecting a CD

1. Press the Eject button [9]. The SLOPING CONSOLE opens and a CD ejects. "EJECT" appears in the display.

⚠ CAUTION

Be careful not to get your fingers caught when opening and closing the SLOPING CONSOLE.

2. Remove the CD and press OPEN button [9] to close the SLOPING CONSOLE.

Notes:

- Be sure to close the SLOPING CONSOLE after removing the CD.
- The SLOPING CONSOLE closes automatically 30 seconds after removing the CD.
- * If a CD (12 cm) is left in the ejected position for 15 seconds, the CD is automatically reloaded. (Auto reload)
- * 3" CDs (8 cm) are not auto reloaded. Be sure to remove it when ejected.

Notes:

- If you force a CD into before auto reloading, this can damage the CD.
- The radio mode is selected automatically 4 seconds after Eject button [9] is pressed.

Selecting a track

● Track-up

1. Press the right side of SEARCH button [2] to move ahead to the beginning of the next track.
2. Each time you press the right side of SEARCH button [2], the track advances ahead to the beginning of the next track.

● Track-down

1. Press the left side of SEARCH button [2] to move back to the beginning of the current track.
2. Press the left side of SEARCH button [2] twice to move to the beginning of the previous track.

Fast-forward/fast-backward

● Fast-forward

Press and hold the right side of SEARCH button [2] for 1 second or longer.

● Fast-backward

Press and hold the left side of SEARCH button [2] for 1 second or longer.

Top function

The top function resets the CD player to the first track of the disc. Press TOP button [4] to play the first track (track No. 1) on the disc.

Scan play

The scan play locates and plays the first 10 seconds of each track on a disc automatically. This function continues on the disc until it is canceled.

* The scan play is useful when you want to select a desired track.

1. Press the number "1" of Direct buttons [13] to start scan play. "SCN" lights in the display.
2. To cancel the scan play, press the number "1" of Direct buttons [13] again. "SCN" goes off from the display and the current track continues to play.

Repeat play

The repeat play continuously plays the current track. This function continues automatically until it is canceled.

1. Press the number "2" of Direct buttons [13]. "RPT" lights in the display and the current track is repeated.
2. To cancel the repeat play, press the number "2" of Direct buttons [13] again. "RPT" goes off from the display and normal play resumes.

Random play

The random play selects and plays individual tracks on a disc in no particular order. This function continues automatically until it is canceled.

1. Press the number "3" of Direct buttons [13]. "RDM" lights in the display, an individual track is selected randomly and play begins.
2. To cancel the random play, press the number "3" of Direct buttons [13] again. "RDM" goes off and normal play resumes.

Setting the clock

1. Press ADJ button [15] to switch to the adjustment selection display.
2. Press the right or left side of SEARCH button [2] to select "CLOCK".
3. Press ENT button [16].
4. Press the right or left side of SEARCH button [2] to select "AUTO/MANU".
5. Turn the Rotary knob [3] clockwise or counterclockwise to set "AUTO" or "MANU".

AUTO:

Displays the time based on the data from the RDS broadcast.

MANU:

Displays the time from the clock in this unit.

6. Press the right or left side of SEARCH button [2] to select the hour or the minute.
7. Turn the Rotary knob [3] clockwise or counterclockwise to set the correct time.
 - * The clock is displayed in 12-hour format.
8. Press ENT button [16] to store the time into memory.
9. Press ADJ button [15] to return to the previous mode.

Note:

- You cannot set the clock when it is displayed with only the ignition on. If you drain or remove the car's battery or take out this unit, the clock is reset. While setting the clock, if another button or operation is selected, the clock set mode is canceled.

Entering titles

Titles up to 10 characters long can be stored in memory and displayed for TV stations and CDs. The numbers of titles that can be entered for each mode are as follows.

Mode	Number of titles
CD mode	50 titles
TV mode	15 titles

CD changer mode	Number of titles
CDC655z connected	60 titles
CDC655Tz connected	100 titles
CDC1255z connected	50 titles

1. Press FUNC button [5] to select the mode you want to enter a title. (CD, CD changer or TV)
2. Select and play a CD or a CD in the CD changer or tune in to a TV station for which you want to enter the title.

3. If you press and hold TITLE button [17] for 1 second or longer, the display switches to the title input screen.
4. Press the right or left side of SEARCH button [2] to move the cursor.
5. Press one of Direct buttons [13] from "1" to "4" and select the character you want to enter. You can enter title characters as follows by pressing Direct buttons [13] (1 to 6).
 - 1 ... Capital letters
 - 2 ... Small letters
 - 3 ... Numbers/symbols
 - 4 ... Umlauts
 - 5 ... Character centering
 - 6 ... Title clear
6. Turn the Rotary knob [3] clockwise or counterclockwise to select the character to enter.
7. Repeat steps 4 to 6 to enter for the title.
8. Press and hold ENT button [16] for 2 seconds or longer to store the title into memory and cancel title input mode.

Clearing titles

1. Select and play a CD or CD in the CD changer or tune in to a TV station for which you want to clear the title.
2. When you press and hold TITLE button [17] for 1 second or longer, the display switches to the title input screen.
3. Press the number "6" of Direct buttons [13].
4. If you press and hold ENT button [16] for 2 seconds or longer, the title is cleared and title input mode is canceled.

Title list play

You can display a list of titles, then select the disc or broadcast station to listen to from that list.

1. With the unit in radio, CD/MD changer or TV mode, press TITLE button [17].
2. Press BAND button [4] and switch to the band or disc you want to play.
3. Press the right or left side of SEARCH button [2] and select the desired title.
4. When you press ENT button [16], the broadcast or disc of which title you selected starts.

Adjusting the display contrast

You can adjust the display contrast to match the angle of installation of the unit.

- * The factory default setting is "8". (Adjustment level: 1 to 15)

1. Press ADJ button [15] to switch to the adjustment selection display.
2. Press the right or left side of SEARCH button [2] to select "CONTRAST".
3. Press ENT button [16].
4. Turn the Rotary knob [3] clockwise or counterclockwise to adjust the contrast.
5. Pressing ENT button [16] returns to the adjustment selection display.
6. Press ADJ button [15] to return to the previous mode.

Adjusting the dimmer level

You can adjust the reduced illumination level of the dimmer.

- * The factory default setting is "3".
- * To use the dimmer, set the dimmer setting to 1 to 5.

1. Press ADJ button [15] to switch to the adjustment selection display.
2. Press the right or left side of SEARCH button [2] to select "DIMMER".
3. Press ENT button [16]. "DIMMER LEV" appears in the display.
4. Turn the Rotary knob [3] clockwise or counterclockwise to adjust the reduced illumination level of the dimmer.

● 1 to 5:

The dimmer operation is performed depending on the set level 1 to 5.

● OFF:

No dimmer operation is performed.

5. Pressing ENT button [16] returns to the adjustment selection display.
6. Press ADJ button [15] to return to the previous mode.

Setting the SEARCH button illumination (Prism function)

The change in the SEARCH button illumination color according to the unit operating state is called the "Prism function". You can set the illumination pattern you prefer.

- * The factory default setting is "PATTERN 1".

1. Press ADJ button [15] to switch to the adjustment selection display.
2. Press the right or left side of SEARCH button [2] to select "PRISM KEY".
3. Press ENT button [16].

- Turn the Rotary knob [3] clockwise or counterclockwise to set the illumination pattern. Each time you turn the Rotary knob [3], the illumination pattern changes in the following order:

“PATTERN 1” → “PATTERN 2” → “OFF” → “PATTERN 1”...

● **PATTERN 1:**

The color changes for each function mode, station tuning, scanning and other operations.

● **PATTERN 2:**

In addition to the changes in PATTERN 1, the color changes according to the audio level.

● **OFF:**

The color changes according to the function mode.

- Pressing ENT button [16] returns to the adjustment selection display.
- Press ADJ button [15] to return to the previous mode.

Message display

When the unit is powered on or off, a message is displayed. The user can turn this message display ON or OFF.

* The factory default setting is “ON”.

- Press ADJ button [15] to switch to the adjustment selection display.
- Press the right or left side of SEARCH button [2] to select “MESSAGE”.
- Press ENT button [16].
- Turn the Rotary knob [3] clockwise or counterclockwise to set message display ON or OFF.
- Pressing ENT button [16] returns to the adjustment selection display.
- Press ADJ button [15] to return to the previous mode.

Turning the non-fader output adjustment display on/off

When not using the non-fader output, you can put out the “NON-FADER VOL” display.

* The factory default setting is “ON”.

* Even if the level adjustment display is set to “OFF”, signals can be output from the non-fader output.

- Press ADJ button [15] to switch to the adjustment selection display.
- Press the right or left side of SEARCH button [2] to select “NON-FADER”.

- Press ENT button [16].
- Turn the Rotary knob [3] clockwise to set “ON” or counterclockwise to set “OFF”.

● **ON:**

When you press A-M button [14], the “NON-FADER VOL” item is displayed.

* The output level can be adjusted.

● **OFF:**

Even when you press A-M button [14], the “NON-FADER VOL” item is not displayed.

* The output level cannot be adjusted.

- Pressing ENT button [16] returns to the adjustment selection display.
- Press ADJ button [15] to return to the previous mode.

Triggered audio mute for cellular telephones

This unit requires special wiring to mute the audio signal automatically when a cellular telephone rings in the car.

* This function is not compatible with all cellular telephones. Contact your local authorized Clarion dealer for information on proper installation and compatibility.

8. OPERATIONS OF ACCESSORIES

CD Changer Operations

CD changer functions

When an optional CD changer is connected through the CeNET cable, this unit controls all CD changer functions. This unit can control a total of 2 changers (MD and/or CD).

Press FUNC button [5] and select the CD changer mode to start play. If 2 CD changers are connected, press FUNC button [5] to select the CD changer for play.

* If "NO MAG" appears in the display, insert the magazine into the CD changer. "LOADING" appears in the display while the player loads (checks) the magazine.

* If "NO DISC" appears in the display, eject the magazine and insert discs into each slot. Then, reinsert the magazine back into the CD changer.

⚠ CAUTION

CD-ROM discs cannot be played in the CD changer.

Pausing play

1. Press Play/pause button [16] to pause play. "PAUSE" appears in the display.
2. To resume play, press Play/pause button [16] again.

Displaying CD titles

This unit can display title data for CD-text CDs and user titles input with this unit.

1. Press DISP button [11] to display the main display.
2. Each time you press and hold DISP button [11] for 1 second or longer, the title display changes in the following order:
User title (disc) → CD-text title (disc) → CD-text title (track) → user title (disc)...

Note:

• If the CD playing is not a CD-text CD or no user title has been input, "-----" appears in the display.

● Scrolling a CD-text title

When a CD-text title is longer than 11 characters, you can scroll the display as follows.

1. Display the CD-text title (disc or track).
2. Press and hold TITLE button [17] for 1 second or longer. The title scrolls.

Selecting a CD

Each of the Direct button [13] corresponds to a disc loaded into the magazine.

● Selecting a disc from 1 to 6

1. Press S button [12] to display the disc display 1 to 6.
2. Press the corresponding Direct button (1 to 6) [13] to select the desired disc.

● Selecting a disc from 7 to 12 (only when a 12 disc CD changer is used.)

1. Press S button [12] to display the disc display 7 to 12.
2. Press the corresponding Direct button (7 to 12) [13] select the desired disc.

* If a CD is not loaded in a slot of the magazine, pressing Direct button [13] corresponding to its disc number is invalid.

Selecting a track

● Track-up

1. Press the right side of SEARCH button [2] to move ahead to the beginning of the next track.
2. Each time you press the right side of SEARCH button [2], the track advances ahead to the beginning of the next track.

● Track-down

1. Press the left side of SEARCH button [2] to move back to the beginning of the current track.
2. Press the left side of SEARCH button [2] twice to move to the beginning of the previous track.

Fast-forward/fast-backward

● Fast-forward

Press and hold the right side of SEARCH button [2] for 1 second or longer.

● Fast-backward

Press and hold the left side of SEARCH button [2] for 1 second or longer.

Top function

The top function plays from the first track (track No. 1) of the disc.

● When playing a disc 1 to 6

1. Press S button [12] to display the disc display (1 to 6).

2. Press Direct button **[13]** (1 to 6) with the same number as the CD playing.

● **When playing a disc 7 to 12 (only when a 12 disc CD changer is used.)**

1. Press S button **[12]** to display the disc display (7 to 12).
2. Press Direct button **[13]** (7 to 12) with the same number as the CD playing.
 - * If a CD is not loaded in a slot of the magazine, pressing Direct button **[13]** corresponding to its disc number is invalid.

Scan play

The scan play locates and plays the first 10 seconds of each track on a disc automatically. This function continues on the disc until it is canceled.

* The scan play is useful when you want to select a desired track.

1. Press S button **[12]** to display the subdisplay.
2. When you press the number "1" of Direct buttons **[13]**, scan play starts. "SCN" lights in the display.
3. To cancel scan play, press the number "1" of Direct buttons **[13]** again. "SCN" goes off from the display and the current track continues to play.

Disc scan play

The disc scan play locates and plays the first 10 seconds of the first track on each disc in the currently selected CD changer. This function continues automatically until it is canceled.

* The disc scan play is useful when you want to select a desired CD.

1. Press S button **[12]** to display the subdisplay.
2. When you press the number "4" of Direct buttons **[13]**, disc scan play starts. "D.SCN" lights in the display.
3. To cancel disc scan play, press the number "4" of Direct buttons **[13]** again. "D.SCN" goes off from the display and normal disc play continues on the current track.

Repeat play

The repeat play continuously plays the current track. This function continues automatically until it is canceled.

1. Press S button **[12]** to display the subdisplay.

2. When you press the number "2" of Direct buttons **[13]**, repeat play starts. "RPT" lights in the display.
3. To cancel repeat play, press the number "2" of Direct buttons **[13]** again. "RPT" goes off from the display and the unit returns to normal play.

Disc repeat play

After all tracks in the current disc have been played, the disc repeat play automatically replays the current disc over from the first track. This function continues automatically until it is canceled.

1. Press S button **[12]** to display the subdisplay.
2. When you press the number "5" of Direct buttons **[13]**, disc repeat play starts. "D.RPT" lights in the display.
3. To cancel disc repeat play, press the number "5" of Direct buttons **[13]** again. "D.RPT" goes off from the display and the unit returns to normal play from the track being played.

Random play

The random play selects and plays individual tracks on the disc in no particular order. This function continues automatically until it is canceled.

1. Press S button **[12]** to display the subdisplay.
2. When you press the number "3" of Direct buttons **[13]**, random play starts. "RDM" lights in the display.
3. To cancel random play, press the number "3" of Direct buttons **[13]** again. "RDM" goes off from the display and the unit returns to normal play.

Disc random play

The disc random play selects and plays individual tracks or discs automatically in no particular order. This function continues automatically until it is canceled.

1. Press S button **[12]** to display the subdisplay.
2. When you press the number "6" of Direct buttons **[13]**, disc random play starts. "D.RDM" lights in the display.
3. To cancel disc random play, press the number "6" of Direct buttons **[13]** again. "D.RDM" goes off from the display and the unit returns to normal play from the track being played.

MD Changer Operations

MD changer functions

When an optional MD changer is connected through the CeNET cable, this unit controls all MD changer functions. This unit can control a total of 2 changers (MD and/or CD).

Press FUNC button [5] and select the MD changer mode to start play. If 2 MD changers are connected, press FUNC button [5] to select the MD changer for play.

* If "NO DISC" appears in the display, load MDs into the MD changer.

Pausing play

1. Press Play/pause button [16] to pause play. "PAUSE" appears in the display.
2. To resume play, press Play/pause button [16] again.

Switching disc titles and track titles

This unit can display disc titles and track titles already entered on MDs. Titles up to 128 characters long can be displayed by scrolling the titles.

* Titles cannot be entered for MDs with this unit.

1. Press DISP button [11] to display the main display. The disc title or track title is displayed.
2. Each time you press and hold DISP button [11] for 1 second or longer, the display toggles between the disc title and the track title.

● Scrolling titles

When a title is longer than 11 characters, you can scroll through it with the following operation.

1. Display the MD title (disc or track).
2. Press TITLE button [17]. The display scrolls through the title.

Selecting an MD

Each of the Direct button [13] corresponds to an MD loaded into the MD changer.

1. Press S button [12] to display the disc display.
2. Press Direct button [13] (1 to 6) and select the desired MD.

* If an MD is not loaded in a slot of the MD changer, pressing Direct button [13] corresponding to its disc number is invalid.

Selecting a track

● Track-up

1. Press the right side of SEARCH button [2] to move ahead to the beginning of the next track.
2. Each time you press the right side of SEARCH button [2], the track advances ahead to the beginning of the next track.

● Track-down

1. Press the left side of SEARCH button [2] to move back to the beginning of the current track.
2. Press the left side of SEARCH button [2] twice to move to the beginning of the previous track.

Fast-forward/fast-backward

● Fast-forward

Press and hold the right side of SEARCH button [2] for 1 second or longer.

● Fast-backward

Press and hold the left side of SEARCH button [2] for 1 second or longer.

Top function

The top function plays from the first track (track No. 1) of the disc.

1. Press S button [12] to display the disc display.
2. Press Direct button [13] (1 to 6) with the same number as the MD playing.

* If an MD is not loaded in a slot of the MD changer, pressing Direct button [13] corresponding to its disc number is invalid.

Scan play

The scan play locates and plays the first 10 seconds of each track on a disc automatically. This function continues on the disc until it is canceled.

* The scan play is useful when you want to select a desired track.

1. Press S button [12] to display the subdisplay.
2. When you press the number "1" of Direct buttons [13], scan play starts. "SCN" lights in the display.
3. To cancel scan play, press the number "1" of Direct buttons [13] again. "SCN" goes off from the display and the current track continues to play.

Disc scan play

The disc scan play locates and plays the first 10 seconds of the first track on each disc in the currently selected MD changer. This function continues automatically until it is canceled.

* The disc scan play is useful when you want to select a desired MD.

1. Press S button **[12]** to display the subdisplay.
2. When you press the number "4" of Direct buttons **[13]**, disc scan play starts. "D.SCN" lights in the display.
3. To cancel disc scan play, press the number "4" of Direct buttons **[13]** again. "D.SCN" goes off from the display and normal disc play continues on the current track.

Repeat play

The repeat play continuously plays the current track. This function continues automatically until it is canceled.

1. Press S button **[12]** to display the subdisplay.
2. When you press the number "2" of Direct buttons **[13]**, repeat play starts. "RPT" lights in the display.
3. To cancel repeat play, press the number "2" of Direct buttons **[13]** again. "RPT" goes off from the display and the unit returns to normal play.

Disc repeat play

After all the tracks on the current disc have been played, the disc repeat play automatically replays the current disc over from the first track. This function continues automatically until it is canceled.

1. Press S button **[12]** to display the subdisplay.
2. When you press the number "5" of Direct buttons **[13]**, disc repeat play starts. "D.RPT" lights in the display.
3. To cancel disc repeat play, press the number "5" of Direct buttons **[13]** again. "D.RPT" goes off from the display and the unit returns to normal play from the track being played.

Random play

The random play selects and plays individual tracks on the disc in no particular order. This function continues automatically until it is canceled.

1. Press S button **[12]** to display the subdisplay.
2. When you press the number "3" of Direct buttons **[13]**, random play starts. "RDM" lights in the display.
3. To cancel random play, press the number "3" of Direct buttons **[13]** again. "RDM" goes off from the display and the unit returns to normal play.

Disc random play

The disc random play selects and plays individual tracks or discs automatically in no particular order. This function continues automatically until it is canceled.

1. Press S button **[12]** to display the subdisplay.
2. When you press the number "6" of Direct buttons **[13]**, disc random play starts. "D.RDM" lights in the display.
3. To cancel disc random play, press the number "6" of Direct buttons **[13]** again. "D.RDM" goes off from the display and the unit returns to normal play from the track being played.

TV tuner functions

When an optional TV tuner is connected through the CeNET cable, this unit controls all TV tuner functions. To watch TV requires a TV tuner and monitor.

Watching a TV

1. Press FUNC button [5] and select the TV mode.
2. Press BAND button [4] to select the desired TV band (TV1 or TV2). Each time the button is pressed, the input selection toggles between TV1 and TV2.
3. Press the right or left side of SEARCH button [2] to tune in the desired TV station.

Watching a video

The TV tuner has a VTR input terminal to which 1 external device can be connected. Connect a 12V video cassette player (VCP) or video cassette recorder (VCR) to the TV tuner input terminal.

1. Press S button [12] to display the subdisplay.
2. Press the number "6" of Preset buttons [13] and select the VTR.
3. To return to the TV broadcast, press the number "6" of Preset buttons [13] again.

Tuning

There are 3 types of tuning mode available, Seek tuning, manual tuning and preset tuning.

Seek tuning

1. Press BAND button [4] and select the desired TV band (TV1 or TV2).
 - * If "MANU" is lit on the display, press and hold BAND button [4] for 1 second or longer. "MANU" in the display goes off and seek tuning is now available.
2. Press the right or left side of SEARCH button [2] to automatically seek a station. Press the right side of SEARCH button [2] to automatically tune up the frequency band to the next available TV station; press the left side to automatically tune down.

Manual tuning

There are 2 ways available: Quick tuning and step tuning. When you are in the step tuning mode, the frequency changes one step at a time. In quick tuning mode, you can quickly tune the desired frequency.

1. Press BAND button [4] and select the desired band. (TV1 or TV2)

* If "MANU" is not lit in the display, press and hold BAND button [4] for 1 second or longer. "MANU" is lit in the display and manual tuning is now available.

2. Tune into a station.

● Quick tuning:

Press and hold the right or left side of SEARCH button [2] for 1 second or longer to tune in a station.

● Step tuning:

Press the right or left side of SEARCH button [2] to manually tune in a station.

Recalling a preset station

A total of 12 TV stations can be stored (6-TV1 and 6-TV2). This allows you to select your favorite TV stations and store them in memory for later recall.

1. Press BAND button [4] and select the desired TV band. (TV1 or TV2)
2. Press S button [12] to display the preset channel display.
3. To recall a stored TV station, press the desired Preset button [13] to select that station.

* Press and hold one of Preset buttons [13] for 2 seconds or longer to store the current station into the preset memory.

Manual memory

1. Select the desired station with seek tuning, manual tuning or preset tuning.
2. Press S button [12] to display the preset channel display.
3. Press and hold one of Preset buttons [13] for 2 seconds or longer to store the current station to that preset memory.

Auto store

Auto store selects 6 TV stations automatically and stores each one into a preset memory.

If there are not 6 stations with good reception, stations previously stored in memory remain and only the strong stations are stored into memory.

1. Press BAND button [4] and select the desired TV band. (TV1 or TV2)
2. Press S button [12] to display the subdisplay.
3. Press and hold the number "2" of Preset buttons [13] for 2 seconds or longer. The stations with good reception are automatically stored to preset buttons.

Preset scan

Preset scan allows the user to view each preset position before it automatically advances to the next preset. This function is useful for searching for desired TV station in memory.

1. Press S button [12] to display the subdisplay.
2. Press the number "1" of Preset buttons [13].
3. When the desired channel is received, press the number "1" of Preset buttons [13] again.

Setting the TV diver

You can change the reception setting for the TV antenna connected to the TV tuner.

1. Press ADJ button [15] to switch to the adjustment selection display.
2. Press the right or left side of SEARCH button [2] to select "TV DIVER".
3. Press ENT button [16].
4. Turn the Rotary knob [3] clockwise to set to "ON" or counterclockwise to set to "OFF".

● **ON:**

Sets reception emphasizing the visual.

● **OFF:**

Sets the diver setting to OFF.

5. Press ENT button [16].
6. Press ADJ button [15] to return to the previous mode.

DSP control function

If the DSP (DPH7500z), sold separately, is connected to this unit using the CeNET cable, all the functions of the DSP can be controlled.

DSP functions

There are 2 modes available in DPH7500z, easy mode and professional mode. Choose one of them and adjust the sound field and the sound quality.

• **Functions common to each mode:**

Spectrum analyzer display, auto loudness, etc.

• **Easy mode:**

Adjustment using the graphic equalizer function and the DSP function.

• **Professional mode:**

Adjustment using the space equalizer function and the parametric equalizer function.

* When the easy mode is selected, adjustment for the professional mode cannot be made. On the contrary, when the professional mode is selected, adjustment for the easy mode cannot be made.

* For details on functions of each mode, refer to the owner's manual supplied with the DPH7500z.

* Hereafter the graphic equalizer is referred to as a G.EQ, the space equalizer referred to as S.EQ and the parametric equalizer referred to as P.EQ.

Operations common to each mode

Enjoying the spectrum analyzer

This unit can display the spectrum analyzer patterns. There are 6 spectrum analyzer patterns.

1. Press DISP button [11] to select the spectrum analyzer display.
2. Each time you press and hold DISP button [11] for 1 second or longer, the spectrum analyzer patterns are switched.

Setting the sensitivity of the spectrum analyzer

* The factory default setting is "MID".

1. Press ADJ button [15] to switch to the adjustment selection display.
2. Press the right or left side of SEARCH button [2] to select "ANA SENS".
3. Press ENT button [16].
4. Turn the Rotary knob [3] clockwise or counterclockwise to set the sensitivity of the spectrum analyzer.

You can choose one of "LOW", "MID" or "HIGH" for the sensitivity of the spectrum analyzer.

- Pressing ENT button [16] returns to the adjustment selection display.
- Press ADJ button [15] to return to the previous mode.

Output adjustment of auto loudness, subwoofer and playback band

- Press ADJ button [15] to switch to the adjustment selection display.
- Press the right or left side of SEARCH button [2] to select "SOUND".
- Press ENT button [16].
- Press the right or left side of SEARCH button [2] to select the adjustment item.
There are "A.LD LEVEL", "WOOFER OUT", "WOOFER LPF", "HPF" and "TEST TONE" available for the adjustment items.
* For details on each adjustment item, refer to the owner's manual supplied with the DPH7500z.
- Turn the Rotary knob [3] clockwise or counterclockwise to make the adjustment.
- Pressing ENT button [16] returns to the adjustment selection display.
- Press ADJ button [15] to return to the previous mode.

Selecting the easy mode or the professional mode

- * The factory default setting is "EASY".
- Press ADJ button [15] to switch to the adjustment selection display.
 - Press the right or left side of SEARCH button [2] to select "DSP/EQ SEL".
 - Press ENT button [16].
 - Turn the Rotary knob [3] clockwise or counterclockwise to set the mode to "EASY" or "PRO".
 - Pressing ENT button [16] returns to the adjustment selection display.
 - Press ADJ button [15] to return to the previous mode.

Entering titles

You can give a title to the user memory of the DSP, G.EQ, S.EQ and P.EQ that you have adjusted yourself.

- Press A-M button [14] to select the adjustment mode in which you want to give a title.
- Press BAND button [4] to select the "User".

- Press one of Direct buttons [13] to select the user memory to which you want to give a title.
- Press and hold TITLE button [17] for 1 second or longer.
- Press the right or left side of SEARCH button [2] to move the cursor.
- Press numbers "1" to "4" of Direct buttons [13] to select the character you want to enter. When you press numbers "1" to "6" of Direct buttons [13], the following title characters can be entered.
 - ... Capital letters
 - ... Small letters
 - ... Numbers and symbols
 - ... Umlauts
 - ... Character centering
 - ... Title clear

* The title clear font is used to delete a title. To delete the title, perform the title clear operation first and then put it into memory.
- Turn the Rotary knob [3] clockwise or counterclockwise to select the character you want to input.
- Repeat steps 5 to 7 to input the title.
- Press and hold ENT button [16] for 2 seconds or longer to put the title into memory. The title input mode is canceled.

Easy mode/ G.EQ operations

Note:

- The adjustment made in easy mode is not reflected in the adjustment in professional mode. On the contrary, the adjustment made in professional mode is not reflected in the adjustment in easy mode.

G.EQ effect ON/OFF

- * The factory default setting is "ON".
- Press A-M button [14] and select "G.EQ".
 - Press S button [12]. While the "ON" is lit in the display, the G.EQ effect is set to "ON".
 - Press A-M button [14].

Note:

- If the G.EQ effect is set to OFF, the adjustment made in "G.EQ operations" is not reflected in the music source.

Selecting a G.EQ menu

- Press A-M button [14] and select "G.EQ".
- Press BAND button [4] to select "G.EQ Basic".
- Press one of Direct buttons [13] and select the desired G.EQ menu.

- * To select the user memory, press BAND button [4] to select "G.EQ User" and press one of Direct buttons [13].

Editing/storing a G.EQ menu (User memory)

1. Select a G.EQ menu which you want to edit on the basis of.
2. Press ADJ button [15].
3. Press the right or left side of SEARCH button [2] to select the frequency to be adjusted.

There are 50Hz, 100Hz, 200Hz, 400Hz, 1kHz, 3kHz and 12kHz available for the adjustment frequency.

- * For details on each adjustment item, refer to the owner's manual supplied with the DPH7500z.
4. Turn the Rotary knob [3] clockwise or counterclockwise to make the adjustment. The adjustment range is from -12dB to +12dB.
 5. Repeat steps 3 to 4 to complete the adjustment and press ADJ button [15].
 6. Press and hold one of Direct buttons [13] for 2 seconds or longer to store the edited contents.

- * You can give a title to the user memory. For the inputting method of titles, refer to the section "Entering titles" in "Operations common to each mode".

Easy mode/DSP operations

DSP effect ON/OFF

- * The factory default setting is "ON".

1. Press A-M button [14] to select "DSP".
2. Press S button [12]. When the "ON" is lit in the display, the DSP effect is set to "ON".
3. Press A-M button [14].

Note:

- If the DSP effect is set to OFF, the adjustment made in "DSP operations" is not reflected in the music source.

Setting the listening position

1. Press A-M button [14] and select "DSP".
2. Press the right or left side of SEARCH button [2] to set the listening position type.

There are FULL SEAT, FRONT-R (only right seat), FRONT-L (only left seat), FRONT (only front seats), REAR (only rear seats) and PASS available for the listening position types.

- * The factory default setting is "FULL SEAT".

Making fine adjustment of the listening position

1. Upon completion of setting the listening position, press ENT button [16].
2. Press the right or left side of SEARCH button [2] to select "RIGHT or LEFT" or "FRONT or REAR".
3. Turn the Rotary knob [3] clockwise or counterclockwise to adjust the balance and the fader.
4. Press ENT button [16] to return to the DSP mode.

Selecting a DSP menu

1. Press A-M button [14] to select "DSP".
2. Press BAND button [4] to select "DSP Basic 1" or "DSP Basic 2".
3. Press one of Direct buttons [13] and select the desired a DSP menu.
 - * To select the user memory, press BAND button [4] to select "DSP User" and then press one of Direct buttons [13].

Editing/storing a DSP menu (User memory)

1. Select a DSP menu which you want to edit on the basis of.
2. Press ADJ button [15].
3. Press the right or left side of SEARCH button [2] to select the item to be adjusted.

There are EFFECT, DELAY, REAR MIX, REV. TIME or ROOM SIZE and HIGH or LIVENESS available for the items to be adjusted.

- * For details on each adjustment item, refer to the owner's manual supplied with the DPH7500z.

4. Turn the Rotary knob [3] clockwise or counterclockwise to make the adjustment.
5. Repeat steps 3 to 4 to complete the adjustment and press ADJ button [15].
6. Press and hold one of the Direct buttons [13] for 2 seconds or longer to store the edited contents.

- * You can give a title to the user memory. For the inputting method of titles, refer to the section "Entering titles" in "Operations common to each mode".

Professional mode/S.EQ operations

Note:

- The adjustment made in professional mode is not reflected in the adjustment in easy mode. On the contrary, the adjustment made in easy mode is not reflected in the adjustment in professional mode.

S.EQ effect ON/OFF

- * The factory default setting is "ON".

1. Press A-M button [14] and select "S.EQ".
2. Press S button [12]. While the "ON" is lit in the display, the S.EQ effect is set to "ON".
3. Press A-M button [14].

Note:

- If the S.EQ effect is set to OFF, the adjustment made in "S.EQ operations" is not reflected in the music source.

Selecting a S.EQ menu

1. Press A-M button [14] to select "S.EQ".
2. Press BAND button [4] to select "S.EQ Basic".
3. Press one of Direct buttons [13] and select the desired S.EQ menu.

- * To select the user memory, press BAND button [4] to select "S.EQ User" and then press one of Direct buttons [13].

Editing/storing a S.EQ menu (User memory)

1. Select a S.EQ menu which you want to edit on the basis of.
2. Press ADJ button [15].
3. Press the right or left side of SEARCH button [2] to select the item to be adjusted.

There are DIFFUSE, CAR WIDTH and CAR LENGTH available for the items to be adjusted.

- * For details on each adjustment item, refer to the owner's manual supplied with the DPH7500z.
4. Turn the Rotary knob [3] clockwise or counterclockwise to make the adjustment. The adjustment range is to 1 to 10 for each item.
 5. Repeat steps 3 to 4 to complete the adjustment and press ADJ button [15].
 6. Press and hold one of Direct buttons [13] for 2 seconds or longer to store the edited contents.

- * You can give a title to the user memory. For the inputting method of titles, refer to the section "Entering titles" in "Operations common to each mode".

Professional mode/P.EQ operations

P.EQ effect ON/OFF

- * The factory default setting is "ON".

1. Press A-M button [14] to select "P.EQ".
2. Press S button [12]. While the "ON" is lit in the display, the P.EQ effect is set to "ON".
3. Press A-M button [14].

Note:

- If the P.EQ effect is set to OFF, the adjustment made in "P.EQ operations" is not reflected in the music source.

Selecting a P.EQ menu

1. Press A-M button [14] to select "P.EQ".
2. Press BAND button [4] to select "P.EQ Basic".
3. Press one of the Direct buttons [13] and select the desired P.EQ menu.

- * To select the user memory, press BAND button [4] to select "P.EQ User" and then press one of Direct buttons [13].

Editing/storing a P.EQ menu (User memory)

1. Select a P.EQ menu which you want to edit on the basis of.
2. Press ADJ button [15].
3. Press the right or left side of SEARCH button [2] to select the item to be adjusted.

There are selections of correction channel, correction band, the center frequency, the Q-curve and gain adjustment available for the items to be adjusted.

- * For details on each adjustment item, refer to the owner's manual supplied with the DPH7500z.
4. Turn the Rotary knob [3] clockwise or counterclockwise to make the adjustment.
 5. Repeat steps 3 to 4 to complete the adjustment and press ADJ button [15].
 6. Press and hold one of Direct buttons [13] for 2 seconds or longer to store the edited contents.

- * You can give a title to the user memory. For the inputting method of titles, refer to the section "Entering titles" in "Operations common to each mode".

9. TROUBLESHOOTING

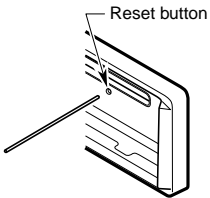
	Problem	Cause	Measure
General	Power does not turn on. (No sound is produced.)	Fuse is blown.	Replace with a fuse of the same amperage. If the fuse blows again, consult your store of purchase.
		Incorrect wiring.	Consult your store of purchase.
	Nothing happens when buttons are pressed. Display is not accurate.	The microprocessor has malfunctioned due to noise, etc.	Turn off the power, then press Release button [1] and remove the DCP. Press the reset button for about 2 seconds with a thin rod. 
	DCP or source unit connectors are dirty.		Wipe the dirt off with a soft cloth moistened with cleaning alcohol.
CD	Compact disc cannot be loaded.	Another compact disc is already loaded.	Eject the compact disc before loading the new one.
		There is a disc other than a CD or foreign matter already in place.	Press and hold OPEN button [9] for 2 seconds or longer. The foreign matter is forcibly ejected.
	Sound skips or is noisy.	Compact disc is dirty.	Clean the compact disc with a soft cloth.
		Compact disc is heavily scratched or warped.	Replace with a compact disc with no scratches.
	Sound is bad directly after power is turned on.	Water droplets may form on the internal lens when the car is parked in a humid place.	Let dry for about 1 hour with the power on.
DSP	Poor sound quality	The equalizer levels are too high.	If the equalizer levels are too high, the sound may distort. Lower the equalizer levels.

10. ERROR DISPLAYS

If an error occurs, one of the following displays is displayed.
Take the measures described below to eliminate the problem.

	Error Display	Cause	Measure
CD	ERROR 2	A CD is caught inside the CD deck and is not ejected.	This is a failure of CD deck's mechanism and consult your store of purchase.
	ERROR 3	A CD cannot be played due to scratches, etc.	Replace with a non-scratched, non-warped disc.
	ERROR 6	A CD is loaded upside-down inside the CD deck and does not play.	Eject the disc then reload it properly.
CD changer	ERROR 2	A CD inside the CD changer is not loaded.	This is a failure of CD changer's mechanism and consult your store of purchase.
	ERROR 3	A CD inside the CD changer cannot be played due to scratches, etc.	Replace with a non-scratched, non-warped disc.
	ERROR 6	A CD inside the CD changer cannot be played because it is loaded upside-down.	Eject the disc then reload it properly.
MD changer	ERROR H	Displayed when the temperature in the MD changer is too high and playback has been stopped automatically.	Lower the surrounding temperature and wait for a while to cool off MD changer.
	ERROR 2	An MD inside the MD changer is not loaded.	This is a failure of MD changer's mechanism and consult your store of purchase.
	ERROR 3	An MD inside the MD changer cannot be played due to scratches, etc.	Replace with a non-scratched, non-warped disc.
	ERROR 6	An MD inside the MD changer cannot be played because it is loaded upside-down.	Eject the disc then reload it properly.
		Displayed when a non-recorded MD is loaded in the MD changer.	Load a pre-recorded MD in the MD changer.

If an error display other than the ones described above appears, press the reset button. If the problem persists, turn off the power and consult your store of purchase.

11. SPECIFICATIONS

FM Tuner

Frequency Range:

87.9 MHz to 107.9 MHz

Usable Sensitivity:

11 dBf

50dB Quieting Sensitivity:

17 dBf

Alternate Channel Selectivity:

75 dB

Stereo Separation (1 kHz):

35 dB

Frequency Response (± 3 dB):

30 Hz to 15 kHz

AM Tuner

Frequency Range:

530 kHz to 1710 kHz

Usable Sensitivity:

25 μ V

CD Player

System:

Compact disc digital audio system

Usable Discs:

Compact disc

Frequency Response (± 1 dB):

5 Hz to 20 kHz

Signal to Noise Ratio (1 kHz):

100 dB

Dynamic Range (1 kHz):

95 dB

Harmonic Distortion:

0.01%

Notes:

- Specifications comply with EIA Standards.
- Specifications and design are subject to change without notice for further improvement.

Audio

Bass Control Action (30 Hz):

± 15 dB

Treble Control Action (10 kHz):

± 10 dB

Line Output Level (CD 1 kHz):

4 V

General

Power Supply Voltage:

14.4 V DC (10.8 to 15.6 V allowable),
negative ground

Current Consumption:

Less than 7 A

Weight / Source unit:

4 lb. (1.8 kg)

Weight / Remote control unit:

1 oz. (30 g) (including battery)

Dimensions / Source unit:

7" (Width) \times 2" (Height) \times 6-2/25" (Depth)
[178 (W) \times 50 (H) \times 152 (D) mm]

Dimensions / Remote control unit:

1-3/4" (Width) \times 4-5/16" (Height) \times 1-1/8" (Depth)
[44 (W) \times 110 (H) \times 27 (D) mm]